

CODAN Mix-Ad Set

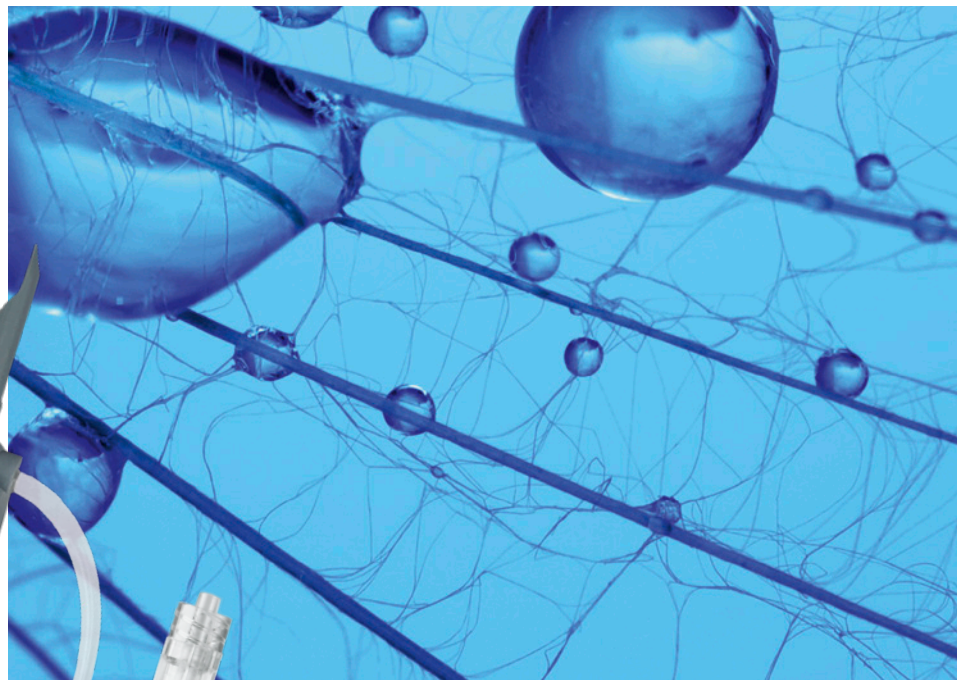

Safe handling of antibiotics

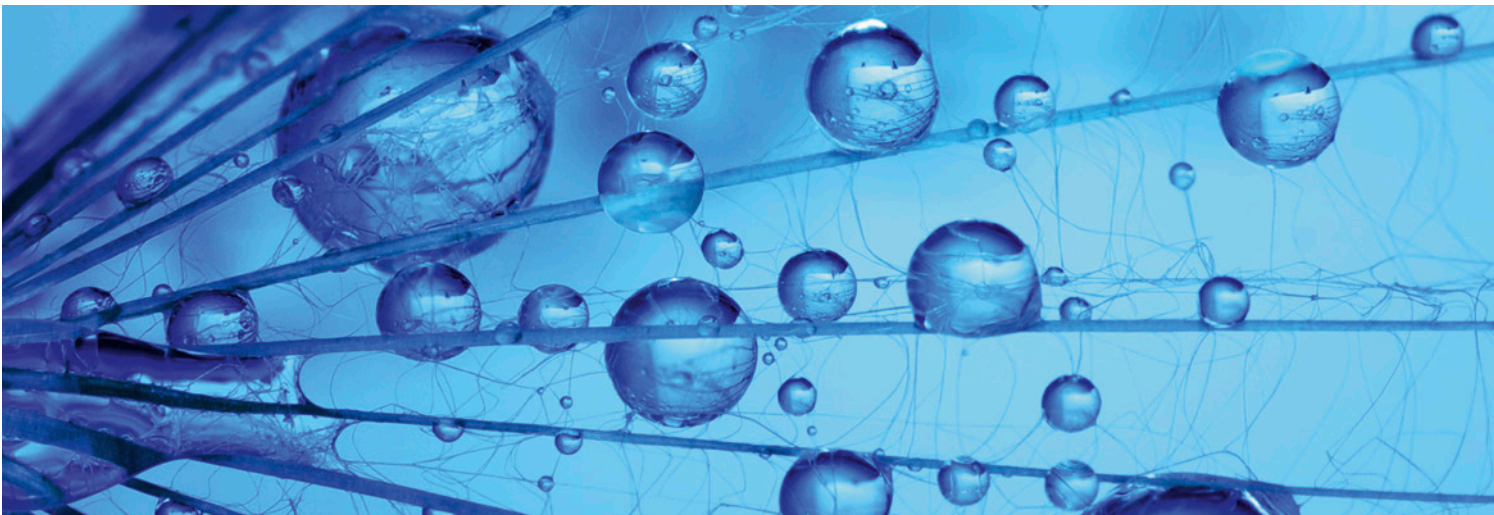
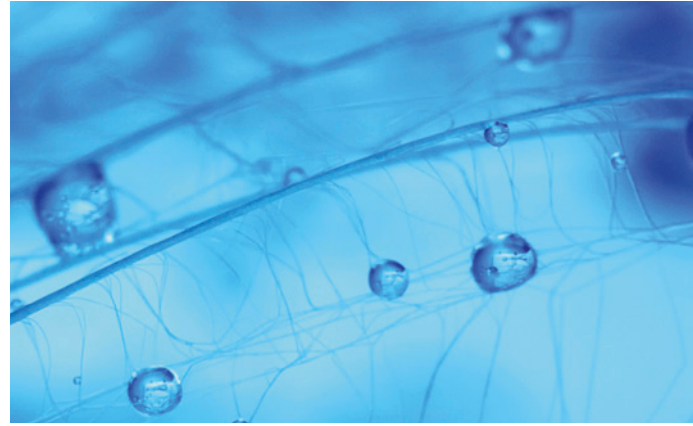

CODAN Mix-Ad Set

Preparation and administration - all in one

Treatment with intravenous antibiotics is one of the most common pharmaceutical therapies in hospital settings, and this carries the risk of exposure to antibiotics for nurses and healthcare medical personnel.

Antibiotics are classified as hazardous pharmaceuticals, therefore healthcare personnel should protect themselves from exposure to them. During the preparation and administration of antibiotics, spills and environmental contamination are common and should be avoided.

The CODAN Mix-Ad Set is a system used to dissolve dried pharmaceuticals and administer the resulting intravenous infusion solution to the patient in one complete system. It is a product specially developed for use with pharmaceuticals that require safe handling with reduced risk of contamination during preparation and administration.

CODAN Mix-Ad Sets have been developed in close collaboration with healthcare professionals; the safety features and user benefits have been amply proven over years of use.

Development

Continuous developments and improvements ensure that our infusion sets for a safe infusion management via sets can be used advantageously in combination with other CODAN products.

Antibiotic resistance

Bacterial infections have been effectively treated with antibiotics since the 1940s. However, the increasing and prolonged use of these pharmaceuticals has caused bacteria to adapt to antibiotic treatment, making antibiotics less effective. Antibiotic resistance is a serious threat to public health as there are no real alternatives. The main cause of resistance is the misuse and unnecessary prescription of antibiotics. Several strategies are being implemented around the world to reduce antibiotic resistance, e.g. judicious use and hygienic precautions to manage contamination. Avoiding exposure to antibiotics is a small but important part of the fight against resistant microorganisms. With CODAN products that ensure safe preparation and administration of these pharmaceuticals, the risk of environmental contamination is reduced.



The use of CODAN Mix-Ad Sets allow a safe handling during the preparation and administration of pharmaceuticals.

Advantages of working with the CODAN Mix-Ad Set

- Reduced exposure to hazardous pharmaceuticals
- Reduced risk of contact allergies
- Simplified working procedures
- Less waste thanks to reduced packaging

CODAN Mix-Ad Sets are already known for their outstanding quality and performance. Now the same benefits are offered in an even more environmentally friendly version:

CODAN green line® Mix-Ad Set is an innovative product line that offers you an alternative to conventional PVC products. These preparation and administration sets are PVC-free which does not only add to health-protection, but also provides a positive contribution to reducing the environmental impact. The green line® Mix-Ad Sets are high-quality products that are also impacting the ecological footprint positively. CODAN takes pride in offering a sustainable solution to fulfil the customer's needs and protecting the environment at the same time. Discover the variety of green line® Mix-Ad Sets from CODAN today and set an example for an environmentally conscious future.

Unique CODAN Components

1. The CODAN designed spike enables all commonly used infusion containers and bags to be penetrated with ease as well as offering a tight and secure fit.

2. The bacteria-tight air filter integrated in the spike ensures sterile ventilation and prevents aerosols.

3. The standard drip rate is 20 drops/1 ml. The flexible, transparent non-reflective material with level ring mark enables easy priming and control of drip rate. Available with a 15 µm filter or a special CODAN Guard® AirStop filter membrane to prevent air infusion.

4. Needle-free Y-site (Y SWAN-LOCK®) with Luer-Lock activated open/close mechanism. The surface of the closed valve is flat and can be easily swabbed for disinfection – capless version.

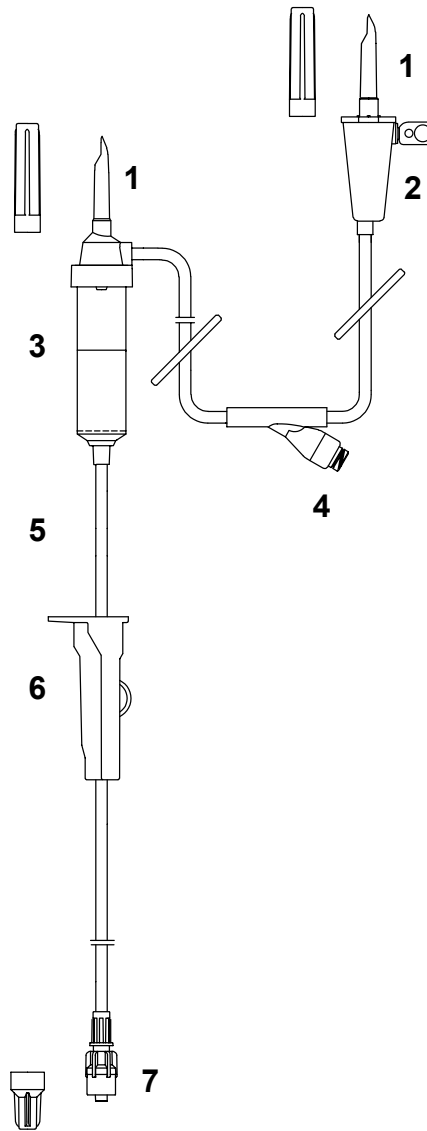

5. CODAN Mix-Ad Sets are available with PVC (TOTM) tubing or with green line® (PVC-free) tubing. Our production has for several years eliminated any use of Latex and DEHP plasticisers.

6. Our CODAN precision roller clamp guarantees a constant flow throughout the whole administration period.

7. Rotating Male Luer-Lock adapter with SELF-LOCK feature for a safe and comfortable connection. The FlowStop protection cap for Male Luer-Lock adapter is equipped with an integrated hydrophobic membrane, ensuring internal sterility prior to use. During priming, the FlowStop protection cap remains attached to the Male Luer-Lock adapter and allows air to pass – as soon as solution reaches the membrane, the flow stops automatically.

The CODAN Mix-Ad Set is available in several variants.



CODAN Guard® Mix-Ad Set/1
(1 Spike)

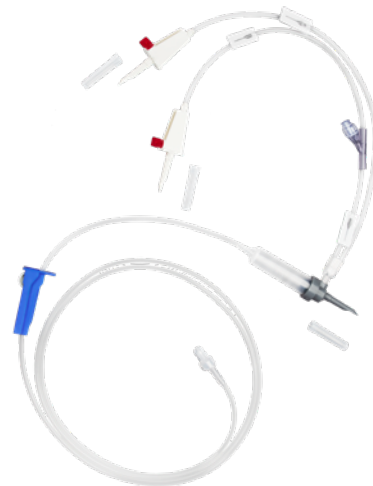

CODAN Guard® Mix-Ad Set/2
(2 Spikes)

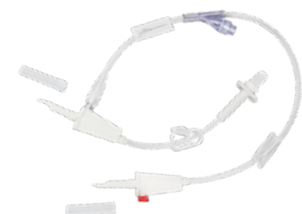

CODAN Mix-Ad Inline/1

CODAN Worldwide



CODAN is known internationally as a manufacturer and supplier of medical transfer systems. The CODAN Companies have more than 1500 employees around the world.

The name CODAN is synonymous with reliability, quality and precision based on the know-how and experience gained from more than 60 years of research and development. Company-owned production facilities and sales companies around the world are a guarantee for efficient production, a tight-knit sales network and a first-class service for customers in the healthcare sector.

CODAN Companies

CODAN Medizinische Geräte GmbH · Deutschland
CODAN pvb Critical Care GmbH · Deutschland
CODAN pvb Medical GmbH · Deutschland
CODAN 11, S.A. · Portugal
CODAN US Corporation · California · USA
CODAN Inc. · California · USA
CODAN NORGE AS · Norge
CODAN TRIPLUS AB · Sverige
CODAN Limited · Great Britain
CODAN FRANCE Sarl · France
CODAN Medical AG · Schweiz
CODAN ARGUS AG · Schweiz
CODAN BV · Nederland
CODAN s.r.l. · Italia
CODAN Medical GmbH · Österreich
CODAN Medical ApS · Danmark
CODAN DEHA ApS · Danmark
CODAN MEDITECH s.r.o. · Česká republika

CODAN Product range

- Infusion sets
- Transfusion sets
- Extension lines and manifold connectors
- Infusion and transfusion accessories
- Infusion filters and filter systems
- Neonatology/Paediatric products
- Withdrawal, preparation and administration systems
- CODAN CYTO®
- Chemoprotect® products
- Single use syringes
- Invasive blood pressure monitoring systems
- Infusion pumps
- Other CODAN Products

Compliance of the established quality management systems with the provisions of EN ISO 13485, the Council Directive 93/42/EEC and/or Regulation (EU) 2017/745 has been certified by the relevant, competent notified bodies:

TÜV SÜD Product Service GmbH

CODAN Medizinische Geräte GmbH
23738 Lensahn, Germany
CODAN pvb Critical Care GmbH
85661 Forstinning, Germany
CODAN US Corporation · Santa Ana, CA 92704, USA
CODAN ARGUS AG · 6340 Baar, Switzerland

Presafe Denmark A/S

CODAN Medical ApS · 4970 Rødby, Denmark

Manufacturer

CODAN Medizinische Geräte GmbH
Stig Husted-Andersen Straße 11 · 23738 Lensahn, Germany
Tel. +49 (0) 43 63 · 51 11 · Fax +49 (0) 43 63 · 51 12 14
codan@codan.de · www.codancompanies.com



The decisive connection